

Short & long arm wind vane

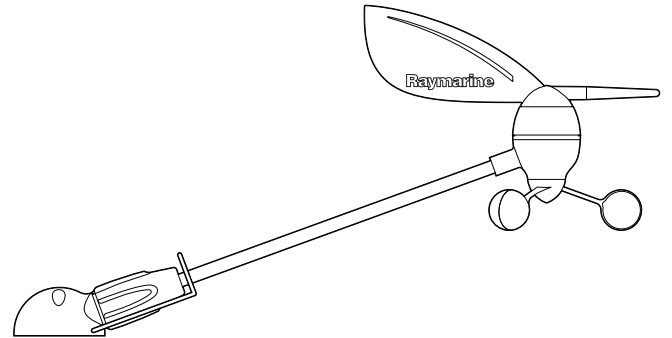

Installation instructions

English

Date: 06-2014

Document number: 87220-1-EN

© 2014 Raymarine UK Limited

Trademark and patents notice

Autohelm, hsb², RayTech Navigator, Sail Pilot, SeaTalk, SeaTalk^{NG}, SeaTalk^{HS} and Sportpilot are registered trademarks of Raymarine UK Limited. RayTalk, Seahawk, Smartpilot, Pathfinder and Raymarine are registered trademarks of Raymarine Holdings Limited.

FLIR is a registered trademark of FLIR Systems, Inc. and/or its subsidiaries.

All other trademarks, trade names, or company names referenced herein are used for identification only and are the property of their respective owners.

This product is protected by patents, design patents, patents pending, or design patents pending.

Fair Use Statement

You may print no more than three copies of this manual for your own use. You may not make any further copies or distribute or use the manual in any other way including without limitation exploiting the manual commercially or giving or selling copies to third parties.

Software updates

Check the website www.raymarine.com for the latest software releases for your product.

Product handbooks

The latest versions of all English and translated handbooks are available to download in PDF format from the website www.raymarine.com.

Please check the website to ensure you have the latest handbooks.

Copyright ©2014 Raymarine UK Ltd. All rights reserved.

Contents

Chapter 1 Important information.....	7	Chapter 10 Spares and accessories	35
Certified Installation	7	10.1 Wind vane spares and accessories	36
Water ingress	7		
Disclaimer	7		
EMC installation guidelines	7		
Suppression ferrites	7		
Connections to other equipment	8		
Declaration of conformity.....	8		
Product disposal.....	8		
Warranty registration.....	8		
IMO and SOLAS.....	8		
Technical accuracy	8		
Chapter 2 Document and product information.....	9		
2.1 Document information	10		
2.2 Further information.....	10		
Chapter 3 Planning the installation	11		
3.1 Installation checklist	12		
3.2 Compatible instrument displays.....	12		
3.3 Parts supplied	13		
3.4 Tools required	13		
3.5 Typical system	14		
3.6 Warnings and cautions	15		
3.7 Wind vane transducer / rotavecta location requirements	15		
3.8 Product dimensions.....	16		
Chapter 4 Mounting.....	17		
4.1 Replacing an existing wind vane	18		
4.2 Mounting the junction box	18		
4.3 Surface mounting.....	19		
Chapter 5 Cables and connections.....	21		
5.1 General cabling guidance	22		
5.2 Cable routing	22		
5.3 Junction box connections.....	23		
5.4 Wind vane connections	23		
Chapter 6 Operation	25		
6.1 Calibration and linearization	26		
6.2 Further information.....	26		
Chapter 7 Maintenance	27		
7.1 Routine checks	28		
7.2 Unit cleaning instructions	28		
Chapter 8 Technical support	29		
8.1 Raymarine customer support	30		
Chapter 9 Technical specification.....	31		
9.1 Physical specification – short arm wind vane	32		
9.2 Physical specification – long arm wind vane.....	32		
9.3 Conformance specification.....	33		

Chapter 1: Important information

Disclaimer

Raymarine does not warrant that this product is error-free or that it is compatible with products manufactured by any person or entity other than Raymarine.

Raymarine is not responsible for damages or injuries caused by your use or inability to use the product, by the interaction of the product with products manufactured by others, or by errors in information utilized by the product supplied by third parties.

Certified Installation

Raymarine recommends certified installation by a Raymarine approved installer. A certified installation qualifies for enhanced product warranty benefits. Contact your Raymarine dealer for further details, and refer to the separate warranty document packed with your product.



Warning: Product installation and operation

This product must be installed and operated in accordance with the instructions provided. Failure to do so could result in personal injury, damage to your vessel and/or poor product performance.



Warning: Potential ignition source

This product is NOT approved for use in hazardous/flammable atmospheres. Do NOT install in a hazardous/flammable atmosphere (such as in an engine room or near fuel tanks).



Warning: Positive ground systems

Do not connect this unit to a system which has positive grounding.

Caution: Power supply protection

When installing this product ensure the power source is adequately protected by means of a suitably-rated fuse or automatic circuit breaker.

Caution: Service and maintenance

This product contains no user serviceable components. Please refer all maintenance and repair to authorized Raymarine dealers. Unauthorized repair may affect your warranty.

Water ingress

Water ingress disclaimer

Although the waterproof rating capacity of this product meets the stated IPX standard (refer to the product's *Technical Specification*), water intrusion and subsequent equipment failure may occur if the product is subjected to commercial high-pressure washing. Raymarine will not warrant products subjected to high-pressure washing.

EMC installation guidelines

Raymarine equipment and accessories conform to the appropriate Electromagnetic Compatibility (EMC) regulations, to minimize electromagnetic interference between equipment and minimize the effect such interference could have on the performance of your system

Correct installation is required to ensure that EMC performance is not compromised.

Note: In areas of extreme EMC interference, some slight interference may be noticed on the product. Where this occurs the product and the source of the interference should be separated by a greater distance.

For **optimum** EMC performance we recommend that wherever possible:

- Raymarine equipment and cables connected to it are:
 - At least 1 m (3 ft) from any equipment transmitting or cables carrying radio signals e.g. VHF radios, cables and antennas. In the case of SSB radios, the distance should be increased to 7 ft (2 m).
 - More than 2 m (7 ft) from the path of a radar beam. A radar beam can normally be assumed to spread 20 degrees above and below the radiating element.
- The product is supplied from a separate battery from that used for engine start. This is important to prevent erratic behavior and data loss which can occur if the engine start does not have a separate battery.
- Raymarine specified cables are used.
- Cables are not cut or extended, unless doing so is detailed in the installation manual.

Note: Where constraints on the installation prevent any of the above recommendations, always ensure the maximum possible separation between different items of electrical equipment, to provide the best conditions for EMC performance throughout the installation

Suppression ferrites

Raymarine cables may be fitted with suppression ferrites. These are important for correct EMC performance. If a ferrite has to be removed for any

purpose (e.g. installation or maintenance), it must be replaced in the original position before the product is used.

Use only ferrites of the correct type, supplied by Raymarine authorized dealers.

Where an installation requires multiple ferrites to be added to a cable, additional cable clips should be used to prevent stress on the connectors due to the extra weight of the cable.

Connections to other equipment

Requirement for ferrites on non-Raymarine cables

If your Raymarine equipment is to be connected to other equipment using a cable not supplied by Raymarine, a suppression ferrite **MUST** always be attached to the cable near the Raymarine unit.

Declaration of conformity

Raymarine UK Ltd. declares that this product is compliant with the essential requirements of EMC directive 2004/108/EC.

The original Declaration of Conformity certificate may be viewed on the relevant product page at www.raymarine.com.

Product disposal

Dispose of this product in accordance with the WEEE Directive.



The Waste Electrical and Electronic Equipment (WEEE) Directive requires the recycling of waste electrical and electronic equipment. Whilst the WEEE Directive does not apply to some Raymarine products, we support its policy and ask you to be aware of how to dispose of this product.

Warranty registration

To register your Raymarine product ownership, please visit www.raymarine.com and register online.

It is important that you register your product to receive full warranty benefits. Your unit package includes a bar code label indicating the serial number of the unit. You will need this serial number when registering your product online. You should retain the label for future reference.

IMO and SOLAS

The equipment described within this document is intended for use on leisure marine boats and workboats NOT covered by International Maritime Organization (IMO) and Safety of Life at Sea (SOLAS) Carriage Regulations.

Technical accuracy

To the best of our knowledge, the information in this document was correct at the time it was produced. However, Raymarine cannot accept liability for any inaccuracies or omissions it may contain. In addition, our policy of continuous product improvement may change specifications without notice. As a result, Raymarine cannot accept liability for any differences between the product and this document. Please check the Raymarine website (www.raymarine.com) to ensure you have the most up-to-date version(s) of the documentation for your product.

Chapter 2: Document and product information

Chapter contents

- [2.1 Document information on page 10](#)
- [2.2 Further information on page 10](#)

2.1 Document information

This document contains important information related to the installation of your Raymarine product.

The document includes information to help you:

- plan your installation and ensure you have all the necessary equipment;
- install and connect your product as part of a wider system of connected marine electronics;
- troubleshoot problems and obtain technical support if required.

This and other Raymarine product documents are available to download in PDF format from www.raymarine.com.

Applicable products

This document is applicable to the following products:

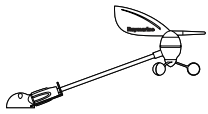
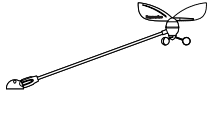
	Part number	Description
	E22078	Short arm wind vane transducer Provides both wind speed and wind direction data.
	E22079	Long arm wind vane transducer Provides both wind speed and wind direction data.

Product documentation

The following documentation is applicable to your product:

Description	Part number
Short & long arm wind vane Installation instructions Installation of a short or long arm wind vane transducer and connection to a wider system of marine electronics.	87220 / 88035
i40 Installation and operation instructions Details the connection and operation of the instrument display in conjunction with a short or long arm wind vane transducer .	81340
i60 Installation and operation instructions Details the connection and operation of the instrument display in conjunction with a short or long arm wind vane transducer .	81342
iTC-5 Installation instructions Details the connection of a short or long arm wind vane transducer to a wider system of marine electronics	87138

Document illustrations

Your product may differ slightly from that shown in the illustrations in this document, depending on product variant and date of manufacture.

All images are provided for illustration purposes only.

2.2 Further information

For detailed operating instructions, refer to the handbook that accompanies your display.

Chapter 3: Planning the installation

Chapter contents

- [3.1 Installation checklist on page 12](#)
- [3.2 Compatible instrument displays on page 12](#)
- [3.3 Parts supplied on page 13](#)
- [3.4 Tools required on page 13](#)
- [3.5 Typical system on page 14](#)
- [3.6 Warnings and cautions on page 15](#)
- [3.7 Wind vane transducer / rotavecta location requirements on page 15](#)
- [3.8 Product dimensions on page 16](#)

3.1 Installation checklist

Installation includes the following activities:

Installation Task	
1	Plan your system.
2	Obtain all required equipment and tools.
3	Site all equipment.
4	Route all cables.
5	Drill cable and mounting holes.
6	Make all connections into equipment.
7	Secure all equipment in place.
8	Power on and test the system.

Schematic diagram

A schematic diagram is an essential part of planning any installation. It is also useful for any future additions or maintenance of the system. The diagram should include:

- Location of all components.
- Connectors, cable types, routes and lengths.

3.2 Compatible instrument displays

The following instrument displays are compatible with your wind transducer.

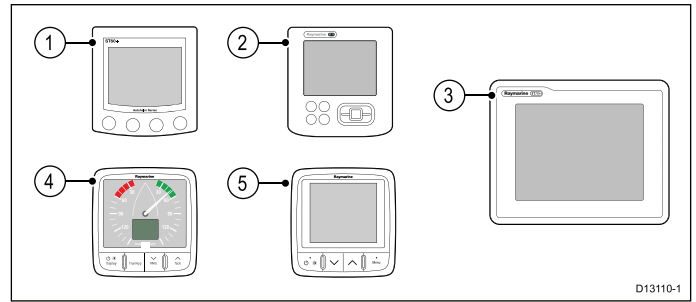







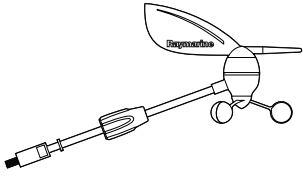
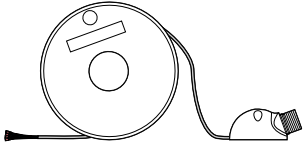

	Description	Comments
1	ST60+ Wind	Direct connection
2	ST70	Via iTC-5 converter or transducer pod
3	ST70+	Via iTC-5 converter or transducer pod
4	i60 Wind	Direct connection
5	i70	Via iTC-5 converter or transducer pod

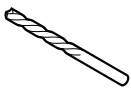
3.3 Parts supplied

The following parts are supplied with your wind vane transducer:

Fixings are provided for various installation scenarios, you do not need to use all of the supplied fixings to install your wind transducer.

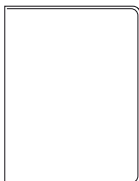
Item	Description	Quantity
	Short arm wind vane assembly / Long arm wind vane assembly	1
	* Cable assembly: • Short arm wind vane supplied with 30 m (98.4 ft.) • Long arm wind vane supplied with 50 m (164 ft.)	1
	Junction box	1
	7-way terminal block	1
	4 mm drill bit	1
	No 4x3/8" pan head pozi screws (junction box fixings)	6
	No 10x3/4" pan head pozi screws (base mounting fixings)	2
	5/32" grommet	2
	2 x double sided adhesive pads	1
	40 mm x 4 mm protective sleeve	2
	Wind arm retaining clip	1
	Document pack	1

Note: * The wind vane base connector is fitted to the end of the cable assembly.

3.4 Tools required

Product installation requires the following tools:

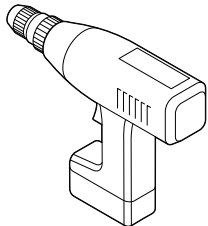
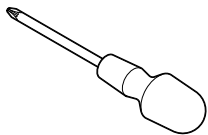
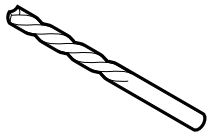
Item	Description	Quantity
	Power drill	1
	Pozidrive screwdriver	1
	Drill bit of appropriate size*	1

Note: * The appropriate drill bit size is dependent on the thickness and material of the mounting surface.

3.5 Typical system

Standalone installation

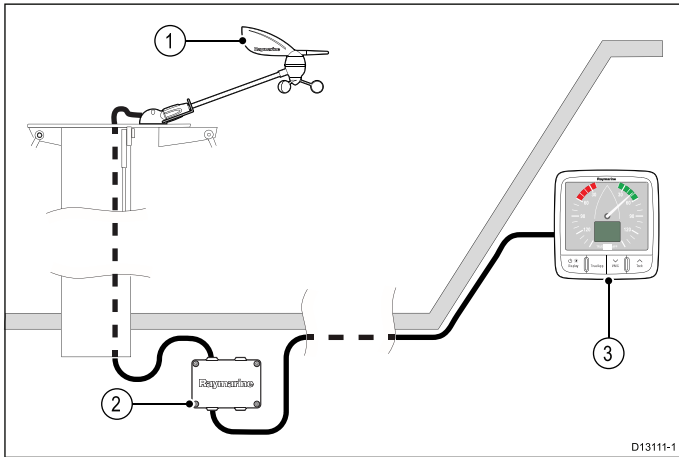

D13111-1

1	Wind vane transducer
2	Junction box
3	Wind instrument display

iTC-5 system example

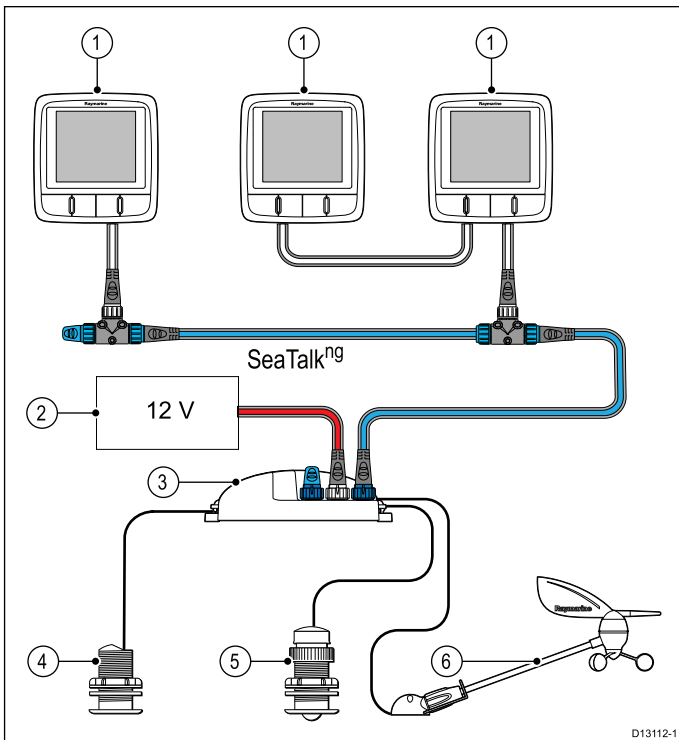

D13112-1

1	SeaTalk ^{ng} instrument displays
2	12 V dc power supply
3	iTC-5 converter
4	Depth transducer
5	Speed transducer
6	Wind vane transducer

SeaTalk^{ng} system example

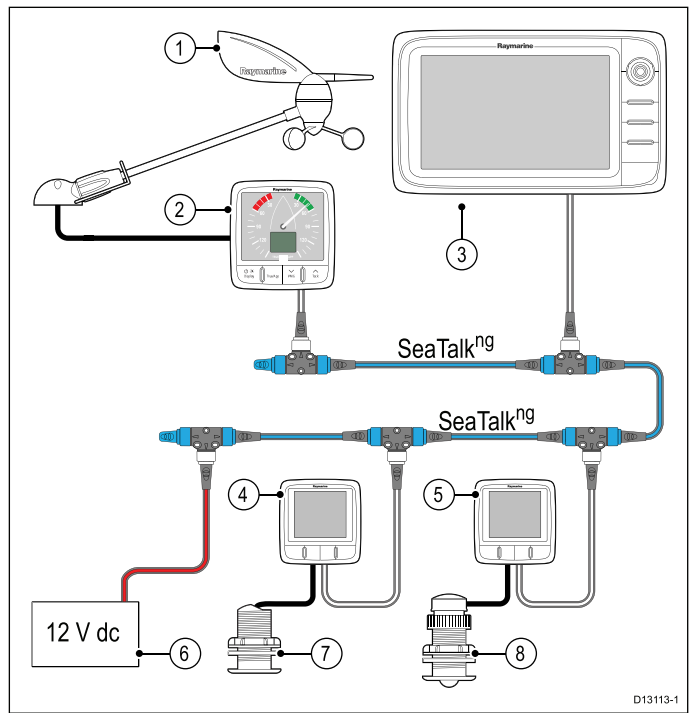

D13113-1

1	Wind vane transducer
2	Wind instrument display (SeaTalk ^{ng})
3	Multifunction display
4	Depth instrument display (SeaTalk ^{ng})
5	Speed instrument display (SeaTalk ^{ng})
6	12 V dc power supply
7	Depth transducer
8	Speed transducer

3.6 Warnings and cautions

Important: Before proceeding, ensure that you have read and understood the warnings and cautions provided in the [Chapter 1 Important information](#) section of this document.

3.7 Wind vane transducer / rotavecta location requirements

When selecting a location for your wind transducer it is important to consider a number of factors.

The transducer's location must:

- Allow reasonable access for installation and servicing.
- Be as high as possible and away from any equipment which may shield the transducer or otherwise disturb the air flow.
- Provide a horizontal mounting surface. If a surface (e.g. mast top) is otherwise suitable but not horizontal, make up a suitable wedged packing piece to provide the necessary horizontal surface.
- There must also be a viable route for the transducer cable to be routed to the product it is to be connected to (i.e. display or converter).

Compass safe distance

To prevent potential interference with the vessel's magnetic compasses, ensure an adequate distance is maintained from the product.

When choosing a suitable location for the product you should aim to maintain the maximum possible distance from any compasses. Typically this distance should be at least 1 m (3 ft) in all directions. However for some smaller vessels it may not be possible to locate the product this far away from a compass. In this situation, when choosing the installation location for your product, ensure that the compass is not affected by the product when it is in a powered state.

3.8 Product dimensions

Short arm wind vane product dimensions

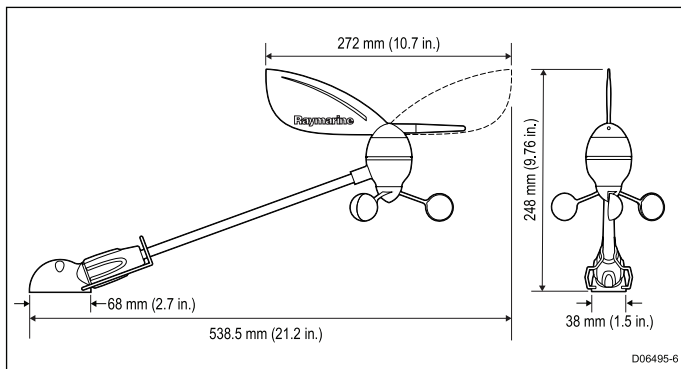

Long arm wind vane product dimensions

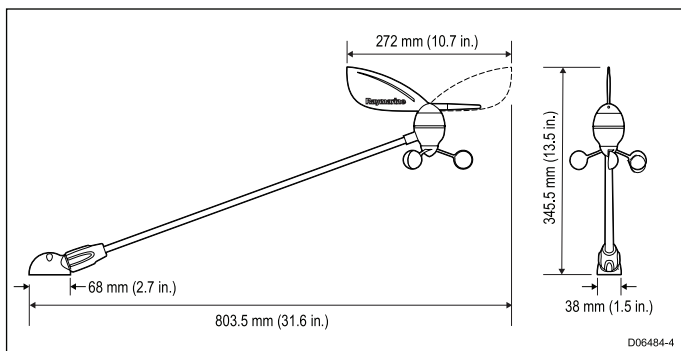

Chapter 4: Mounting

Chapter contents

- [4.1 Replacing an existing wind vane on page 18](#)
- [4.2 Mounting the junction box on page 18](#)
- [4.3 Surface mounting on page 19](#)

4.1 Replacing an existing wind vane

When replacing an existing wind vane you can either fit the new wind vane complete, or you can connect your new wind vane to an existing base. The wind vane can also be connected to an older style base.

If connecting to an older style base you must remove the 'O' ring from inside the older style base before fitting the new wind vane.

1. To connect to an existing base of the same style:
 - i. Unscrew the locking collar and pull the wind vane away from its base.
 - ii. Ensuring correct connector orientation, insert the wind vane assembly into the base.
 - iii. Slide the 'O' ring down the arm towards the base.
 - iv. Tighten the locking collar by turning clockwise until tight.

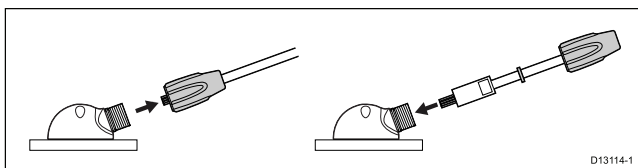

2. To connect to an existing older style base:
 - i. Unscrew the locking collar and pull the wind vane away from its base.
 - ii. Remove the existing 'O' ring from the older style base.
 - iii. Ensuring correct connector orientation, insert the wind vane assembly into the base.
 - iv. Slide the 'O' ring down the arm towards the base.
 - v. Tighten the locking collar by turning clockwise until tight.

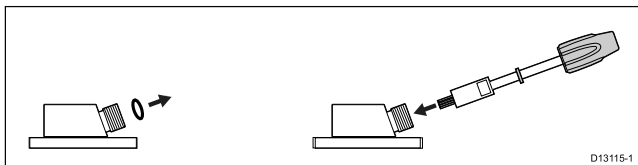

4.2 Mounting the junction box

The junction box can be mounted using the supplied screws or double sided adhesive pads.

The junction box should be mounted below decks, close to the cable entry point.

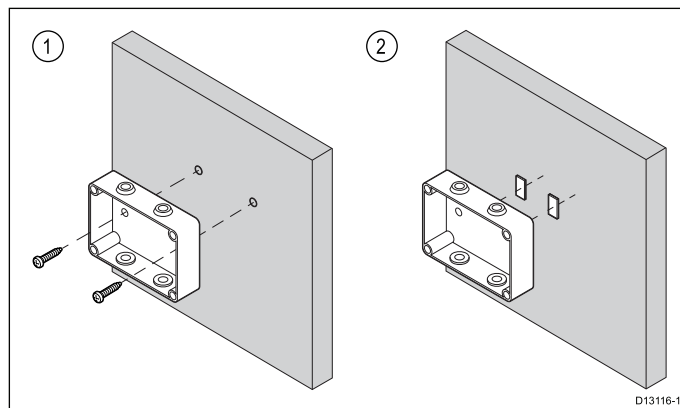

1. To mount the junction box using the fixings screws (supplied) follow the steps below:
 - i. Hold the junction box against the mounting surface at the desired location.
 - ii. Mark the location of the mounting holes on the mounting surface.
 - iii. Drill 2 holes in the mounting surface at the marked locations.
 - iv. Holding the junction box in place, secure to the mounting surface using the supplied screws.
2. To mount the junction box using the double sided pads (supplied) follow the steps below:
 - i. Remove the backing from one side of the double sided adhesive pads
 - ii. Evenly space the adhesive pads and stick to the rear of the junction box.
 - iii. Remove the backing from the opposite side of the adhesive pads.
 - iv. Hold the junction box against the mounting surface at the desired location.
 - v. Apply firm pressure to the front of the junction box to ensure the pads adhere the junction box to the mounting surface.
3. Feed the necessary cables through the grommets in the junction box.
4. Connect the relevant wires together inside the junction box using the terminal block.
5. Place the lid onto the junction box.
6. Use the screws provided to secure the lid to the junction box.

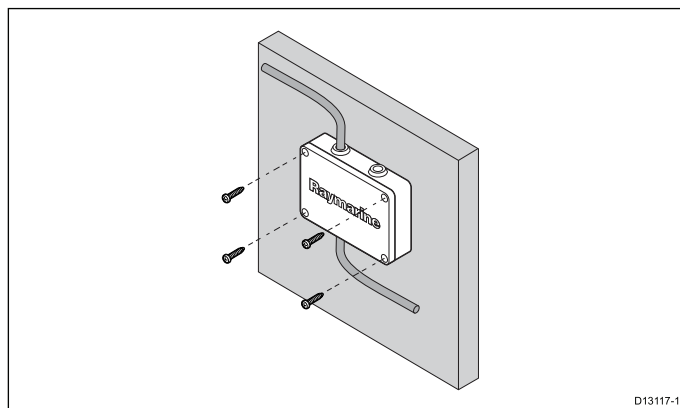

4.3 Surface mounting

Follow the steps below to surface mount your unit on a mast top or radar arch.

The unit must be mounted on a horizontal surface. If the mounting surface is not horizontal, use a packing wedge (not supplied) to make the surface horizontal.

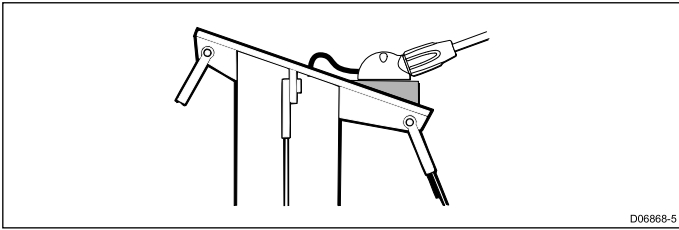

The unit's cable can be routed protruding from the rear of the base or underneath the base as shown below:

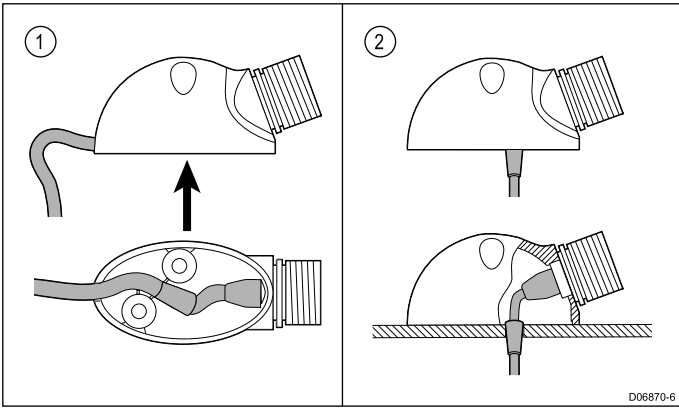

Option 1	Option 2
Cable protrudes from rear of base.	Cable protrudes underneath base.

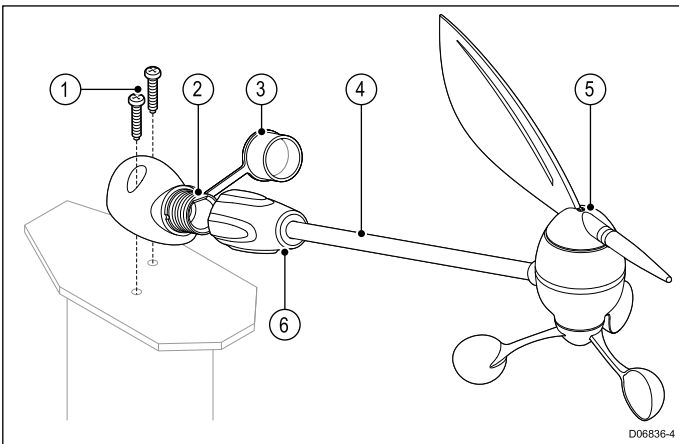

1	Fixing screws
2	Base
3	Protective cap
4	Arm
5	Transducer head
6	Locking collar

Note: Do NOT remove the protective cap from the base connector until you are ready to fit the wind vane arm.

1. Decide on the cable routing option that suits your installation.

2. Mark the mounting surface based on your cable routing option:
 - i. **Option 1** — Place the base of the unit in the desired location, with the connection end facing directly forwards, and mark the position of the mounting holes.
 - ii. **Option 2** — Use the supplied mounting template to mark the position of the mounting holes and the cable hole.
3. Drill holes in the mounting surface based on your chosen cable routing option:
 - i. **Option 1** — Drill a hole at each of the 2 mounting hole locations.
 - ii. **Option 2** — Drill a hole at each of the 2 mounting hole locations and an 8 mm hole for the cable routing.
4. Unreel the unit's cable from the spindle it is supplied on.
5. If option 2 has been chosen or you need to use the junction box, you may need to remove the spade terminals from the end of the cable to feed the cable through the hole in the mounting surface.
6. Using the provided fixings secure the unit's base to the mounting surface, ensuring that the cable does not get squashed between the base and the mounting surface.
7. Remove the protective cap from the connector in the base, ensuring it stays attached to the base .
8. Ensuring correct connector orientation, insert the wind vane assembly into the base.
9. Slide the 'O' ring down the arm towards the base.
10. Tighten the locking collar by turning clockwise until tight.
11. When installing a short arm wind vane, use the retaining clip to secure the arm of the wind vane.

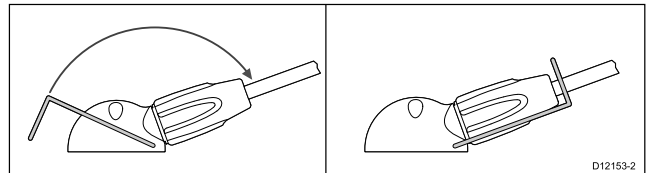

12. Route the cable back to the display, using the junction box if required.
13. If you had to remove the spade terminals then new spade terminals (not supplied) must be fitted to each wire.
14. Connect the spade terminals to the relevant connectors on the back of the display.

Chapter 5: Cables and connections

Chapter contents

- [5.1 General cabling guidance on page 22](#)
- [5.2 Cable routing on page 22](#)
- [5.3 Junction box connections on page 23](#)
- [5.4 Wind vane connections on page 23](#)

5.1 General cabling guidance

Cable types and length

It is important to use cables of the appropriate type and length

- Unless otherwise stated use only standard cables of the correct type, supplied by Raymarine.
- Ensure that any non-Raymarine cables are of the correct quality and gauge. For example, longer power cable runs may require larger wire gauges to minimize voltage drop along the run.

Routing cables

Cables must be routed correctly, to maximize performance and prolong cable life.

- Do NOT bend cables excessively. Wherever possible, ensure a minimum bend diameter of 200 mm (8 in) / minimum bend radius of 100 mm (4 in).

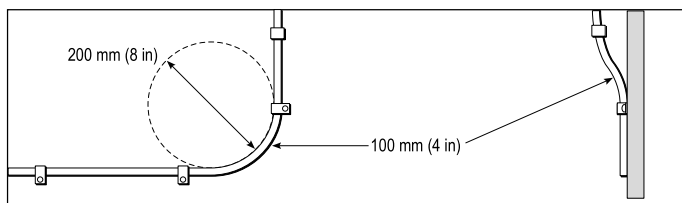

- Protect all cables from physical damage and exposure to heat. Use trunking or conduit where possible. Do NOT run cables through bilges or doorways, or close to moving or hot objects.
- Secure cables in place using tie-wraps or lacing twine. Coil any extra cable and tie it out of the way.
- Where a cable passes through an exposed bulkhead or deckhead, use a suitable watertight feed-through.
- Do NOT run cables near to engines or fluorescent lights.

Always route data cables as far away as possible from:

- other equipment and cables,
- high current carrying ac and dc power lines,
- antennae.

Caution: Pulling cables

Do NOT use cords or ropes, attached to cable connectors, to pull cables through restricted apertures (e.g. as in bulkheads), as this could cause damage to cables.

Strain relief

Ensure adequate strain relief is provided. Protect connectors from strain and ensure they will not pull out under extreme sea conditions.

Cable shielding

Ensure that all data cables are properly shielded that the cable shielding is intact (e.g. hasn't been scraped off by being squeezed through a tight area).

5.2 Cable routing

Routing the cable through the deck mast

Follow the steps below to route cable through a deck mast.

1. Feed the cable down the mast and out through a suitable below-decks aperture.
2. Run the cable back to the display or converter and connect the spade terminals to the relevant connectors.

Routing the cable through a stepped deck mast

Follow the steps below to route cable through a stepped deck mast.

You will require new 1/8th spade terminals to perform this procedure.

1. Remove the existing spade terminals from the end of the cable.
2. Feed the cable down the mast and out through a suitable above-decks aperture.
3. Fit a suitable cable gland to the deck.
4. Pass the cable through the gland and run it back to the display or converter.
5. Crimp the new spade terminals (not supplied) to the end of the cable.
6. Connect the new spade terminals to the relevant connectors on the unit.

Making transducer connections

Although the transducer cable is fitted with spade connectors for direct connection to the rear of the unit, it may be necessary to remove these to facilitate installation, e.g. if the cable has to be routed through narrow apertures. 1/8th spade terminals will be required (not supplied), to replace those removed. When fitting the new spade connectors, prepare the cables as detailed below:

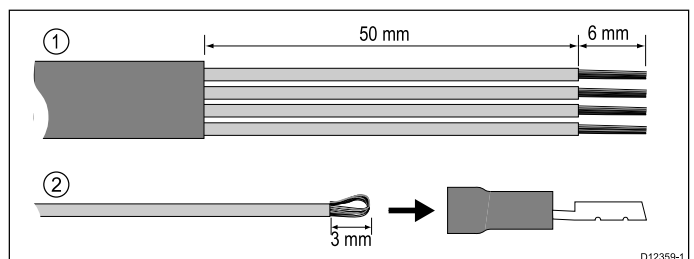

1. Prepare the cable as shown in 1 above.
2. Fold back the wire strands and insert into the new spade connector as shown in 2 above.
3. Ensure the wire strands do not extend beyond the rear of the spade connector insulation.
4. Crimp the connector to the wire.

5.3 Junction box connections

If you need to splice and rejoin the cable then the supplied junction box should be used which ensures that the connections are protected.

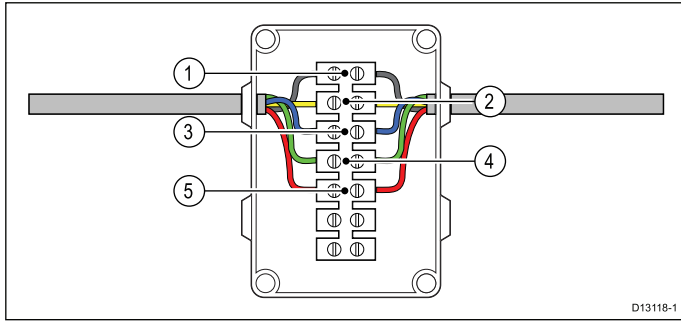

1	Grey	Wind 0 V (Shield)
2	Yellow	Anemometer (signal)
3	Blue	Cosine wind direction
4	Green	Sine wind direction
5	Red	Wind V+

5.4 Wind vane connections

The wind vane should be connected as shown below.

iTC-5 connection

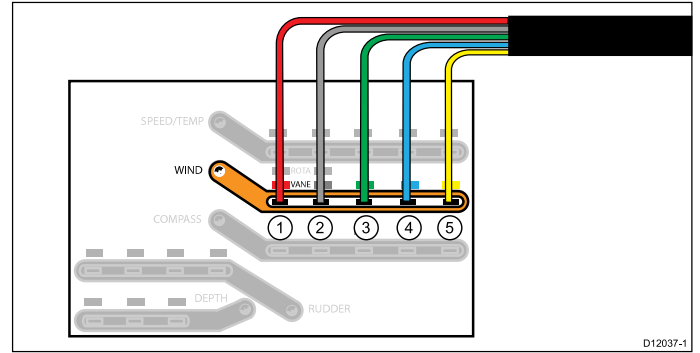

Item	Cable color	Signal name
1.	Red	Wind V+
2.	Screen	Wind 0V (shield)
3.	Green	Sine wind direction
4.	Blue	Cosine wind direction
5.	Yellow	Anemometer (signal)

i60 / ST60 connection

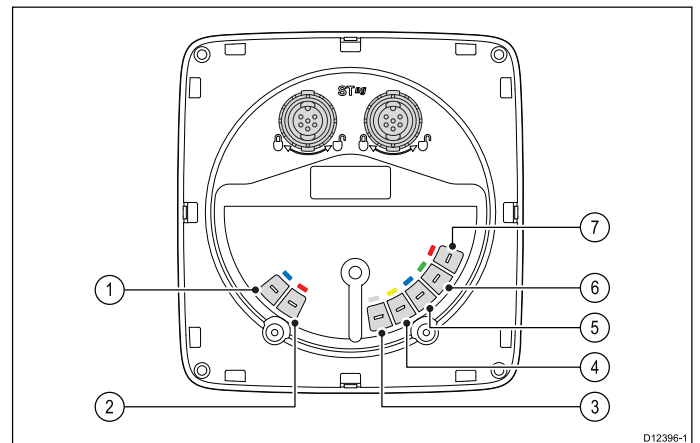

3	Grey	Wind 0 V (Shield)
4	Yellow	Anemometer (signal)
5	Blue	Cosine wind direction
6	Green	Sine wind direction
7	Red	Wind V+

Note: Connectors 3 to 7 are for wind vane transducers, connectors 1 and 2 are rotavecta connections.

Chapter 6: Operation

Chapter contents

- [6.1 Calibration and linearization on page 26](#)
- [6.2 Further information on page 26](#)

6.1 Calibration and linearization

In order to achieve optimum data readings from your transducer it must be calibrated and linearized.

Please refer to the Installation and operation instructions that accompanied your compatible Wind instrument display for calibration and linearization procedures.

6.2 Further information

For detailed operating instructions, refer to the handbook that accompanies your display.

Chapter 7: Maintenance

Chapter contents

- [7.1 Routine checks on page 28](#)
- [7.2 Unit cleaning instructions on page 28](#)

7.1 Routine checks

The following periodic checks should be made:

- Examine cables for signs of damage, such as chafing, cuts or nicks.
- Check that the cable connectors are firmly attached and that their locking mechanisms are properly engaged.

Note: Cable checks should be carried out with the power supply switched off.

Wind Vane maintenance

As part of routine maintenance ensure that:

- You do NOT use Lubricants or sealants.
- The arm's retaining clip is tight and secure.

7.2 Unit cleaning instructions

The unit does not require regular cleaning. However, if you find it necessary to clean the unit, please follow the steps below:

1. Ensure power is switched off.
2. Wipe unit clean with a damp cloth.
3. If necessary, use a mild detergent solution to remove grease marks.

Chapter 8: Technical support

Chapter contents

- [8.1 Raymarine customer support on page 30](#)

8.1 Raymarine customer support

Raymarine provides a comprehensive customer support service. You can contact customer support through the Raymarine website, telephone and e-mail. If you are unable to resolve a problem, please use any of these facilities to obtain additional help.

Web support

Please visit the customer support area of our website at:

www.raymarine.com

This contains Frequently Asked Questions, servicing information, e-mail access to the Raymarine Technical Support Department and details of worldwide Raymarine agents.

Telephone and e-mail support

In the USA:

- **Tel:** +1 603 324 7900
- **Toll Free:** +1 800 539 5539
- **E-mail:** support@raymarine.com

In the UK, Europe, and the Middle East:

- **Tel:** +44 (0)13 2924 6777
- **E-mail:** ukproduct.support@raymarine.com

In Southeast Asia and Australia:

- **Tel:** +61 (0)29479 4800
- **E-mail:** aus.support@raymarine.com

Product information

If you need to request service, please have the following information to hand:

- Product name.
- Product identity.
- Serial number.
- Software application version.
- System diagrams.

You can obtain this product information using the menus within your product.

Chapter 9: Technical specification

Chapter contents

- 9.1 Physical specification – short arm wind vane on page 32
- 9.2 Physical specification – long arm wind vane on page 32
- 9.3 Conformance specification on page 33

9.1 Physical specification – short arm wind vane

Dimensions	<ul style="list-style-type: none"> • Height: 248 mm (9.76 in). • Length: 538.5 mm (21.2 in). • Cup rotation diameter: 272 mm (10.7 in.)
Weight	<ul style="list-style-type: none"> • Boxed: 2.5 Kg (5.5 lbs) • Wind vane assembly: 0.2 (0.4 lbs) • Cable assembly: 1.2 Kg (2.6 lbs)
Cable length	<ul style="list-style-type: none"> • 30 m (98.4 ft.)

9.2 Physical specification – long arm wind vane

Dimensions	<ul style="list-style-type: none"> • Height: 345.5 mm (13.5 in). • Length: 803.5 mm (31.6 in). • Cup rotation diameter: 272 mm (10.7 in.)
Weight	<ul style="list-style-type: none"> • Boxed: 3 Kg (6.6 lbs) • Wind vane assembly: 0.22 Kg (0.47 lbs) • Cable assembly: 1.85 Kg (4 lbs)
Cable length	<ul style="list-style-type: none"> • 50 m (164 ft.)

9.3 Conformance specification

Conformance	<ul style="list-style-type: none">• EN 60945:2002• EMC Directive 2004/108/EC• Australia and New Zealand: C-Tick, Compliance Level 2
--------------------	---

Chapter 10: Spares and accessories

Chapter contents

- [10.1 Wind vane spares and accessories on page 36](#)

10.1 Wind vane spares and accessories

The following spares and accessories are available for the wind vane transducers.

Spares

Description	Part number
Short arm wind vane transducer (no cable)	R28170
Long arm wind vane transducer (no cable)	R28171
Wind vane short arm (300 mm)	A28159
Wind vane long arm (600 mm)	A28160
Wind vane base	A28161
30 m (98.4 ft.) cable assembly (including base)	A28162
50 m (164 ft.) cable assembly (including base)	A28163
Wind vane PCB assembly	A28164
300 mm (11.8 in.) Wind vane arm cable assembly	A28165
600 mm (23.6 in.) Wind vane arm cable assembly	A28166
Wind vane service kit (includes: vane, counterbalance weight, anemometer cups and screws)	A28167
Wind vane top pod kit (includes: bearing, magnet assembly and O-ring seal)	A28168
Connector protective cap	R28169

Accessories

Description	Part number
ST290 active wind pod	E22068
ST70 wind pod	E22108

Raymarine[®]
A FLIR COMPANY