

## ATD Automatic Timer Disconnect 7615

Can be configured to be used as one of the following battery saving products

### Timer Disconnect

- 12V signal triggers relay to connect battery power to devices
- When signal is removed the timer is activated and will disconnect devices after a preset time
- Timer ranges from 15 minutes to 4 hours

### Low Voltage Disconnect

- 12V signal triggers relay to connect battery power to devices
- After 12V signal is removed, ATD senses low battery voltage and automatically disconnects devices
- Low voltage setting can be used in conjunction with Timer Disconnect. Low voltage will disconnect devices prior to preset time to preserve battery power

### Automatic Charging Relay

- Automatically combines two batteries when charging, and isolates them when discharging
- Single side sensing design only monitors the voltage of the start battery
- Ideal for auxiliary batteries that are AGM or significantly larger than the start battery

### Solenoid

- 12V signal will connect or disconnect relay without any time delay

### Specifications

Nominal Voltage	12V DC
Input Voltage Range	9.5–16V
Continuous Rating	120A
Intermittent Rating: 5 min.	210A
(Combine) Amperage Operating Current	175mA
(Open) Amperage Operating Current	4mA
Cable Size to Meet Current Ratings	1 AWG (50mm <sup>2</sup> )
Maximum Cable Size	1/0 AWG (50mm <sup>2</sup> )
Terminal Stud Size	3/8"-16 (M10)
Terminal Stud Torque	140 in-lb (15.82 Nm)
Time Range	15 Minutes – 4 Hours

### Charge Sense ON

Connected (3 sec)	13.0V or greater
Timing (10 sec)	12.75V or lower

### Low Voltage

Disconnected (10 sec)	Battery Voltage < Disconnect Voltage
-----------------------	--------------------------------------

### Over Voltage

Disconnected (5 sec)	16.0V or greater
----------------------	------------------

### Regulatory

CE marked for ignition protection. Meets ISO 8846 and SAE J1171 external ignition protection requirements

IP67 - protected against immersion up to 1 meter for 30 minutes

### Guarantee

Blue Sea Systems stands behind its products for as long as you own them.

Find detailed information at [www.blueseasystems.com/about](http://www.blueseasystems.com/about).

For customer service, call 800-222-7617.

## Installation Instructions

### ⚠ WARNING ⚠

Refers to a potentially hazardous situation which, if not avoided, may result in death or serious injury.

- ✓ Before beginning electrical installation, disconnect all AC and DC power sources.
- ✓ Do not service equipment that has been automatically disconnected by the ATD without first permanently removing power from the equipment by a means other than the ATD.

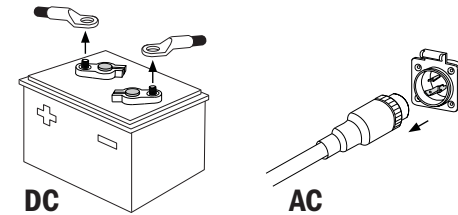

### ⚠ CAUTION ⚠

Refers to a potentially hazardous situation which, if not avoided, may result in minor or moderate injury.

- ✓ If you are not knowledgeable about electrical systems, consult an electrical professional.
- ✓ To avoid corrosion to connecting wires and terminals, mount in a dry and protected location if possible. Avoid locations directly above the battery banks.
- ✓ The ATD is not intended to carry engine starting currents. If the ATD is used as a disconnect, do not wire it in line with the starting circuit. If the ATD is used as an ACR, do not use it to combine batteries for emergency starting. Use a battery switching system with a combine batteries/parallel function if batteries may need to be combined for emergency starting.

### Minimum connections for operation:

- Connect the primary/starting battery to the stud marked BATT.
  - Connect the loads to be disconnected to the stud marked LOAD (or connect the secondary/house battery for ACR applications).
  - Connect the quick connect terminal marked GND (ground) to the DC system ground.
  - Start key / Ignition: Used to trigger the ATD to connect. Wire the quick connect terminal marked "Start Key" through a 1-10A fuse to the accessory position of your ignition switch to enable the ATD to close when the ignition is on.
- NOTE:** The Start key / Ignition connection is optional if and only if the "Charge Sense" DIP switch is enabled, in which case the ATD will be triggered to connect if battery voltage is above 13.0V for 3 seconds.

### Optional Connection:

Remote Indicator LED - mirrors the status LED on the ATD

- Appropriate 12V LEDs include Blue Sea Systems PNs 8033 (amber), 8171 (red), or 8172 (green).
- To install a remote LED indicator, connect the positive (red) wire of the LED to a 12V positive source through a 1-10A inline fuse, and connect the negative (yellow) wire to the quick connect terminal on the ATD marked "LED".

### Dimensioned Drawings

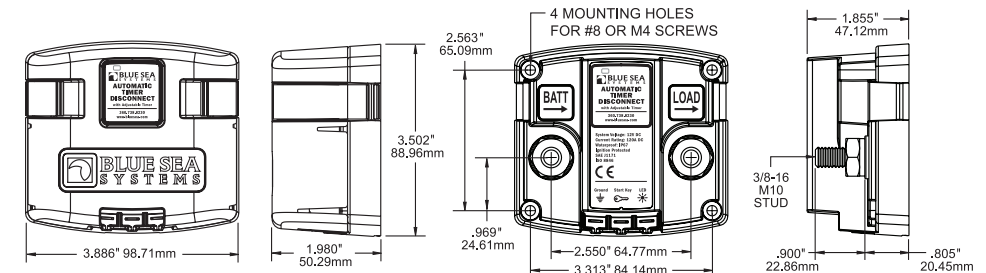

## Setup

There are three behaviors that can be customized for the ATD by setting all six DIP switches on the back side of the device. These behaviors can work together or independently.

### 1. Set Disconnect Time

Amount of time delay before power is disconnected from devices.

Dip Switches 1-3	
Dip Switch Settings	Time
	0 sec
	5 sec
	15 min
	30 min
	1 hr
	1.5 hr
	2 hr
	4 hr

### 2. Set Disconnect Voltage

Low battery voltage that will trigger power disconnect from devices.

Dip Switches 4-5	
Dip Switch Settings	Volts
	Disabled
	11.0V
	11.5V
	12.0V

**Note:** Use a small flat blade screwdriver or other suitable tool to set switches. DIP switch settings are checked by the device once per second. If settings are changed while the device is in timing mode, the timer will be reset to the new value.

### 3. Set Charge Sense

Allows ATD to be either manually activated by a 12V signal or automatically activated by sensing a charging source (i.e. engine alternator).

Dip Switch 6	
Dip Switch Settings	Charge Sense
	Off
	On

### DIP Switches

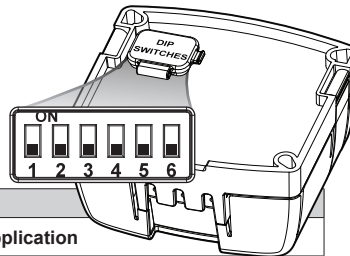

### Example Settings

Dip Switch Settings	Time	Voltage	Charge Sense	Mode	Application
	Disabled	Disabled	Off	Solenoid	Remote Battery Switch
	30 min	Disabled	Off	Timing Only	Ignition Controlled - Delayed off
	Disabled	11.5V	Off	LVD Only	Ignition Controlled - Load shedding
	15 min	11.5V	Off	Timing & LVD	Ignition Controlled - Delayed off with low voltage override
	Disabled	Disabled	On	ACR	Automatic Sensing - Charging a second battery with single alternator
	1 hr	11.0V	On	Timing, LVD, & Charge Sense	Automatic Sensing - Delayed off with low voltage override

State	Conditions to Enter State
<b>Connected</b> Relay Closed LED Solid ON	Ignition ON OR  Charge Sense ON +  Above 13V for 3 sec.
<b>Timing</b> Relay Closed LED Single Flash	Ignition OFF +  Charge Sense OFF OR  Below 12.75V for 10 sec.
<b>Disconnected</b> Relay Open LED OFF	Timer setting expired OR  Below disconnect voltage setting for 10 sec.
<b>Overtoltage</b> Relay Open LED double flash	Above 16V for 5 sec. To clear overvoltage lockout state:  Below 15.9V

## Wire Size and Fuse Ratings

Use the wiring sizing chart below to select the appropriate wire sizes to prevent overheating the ATD. Consult an ABYC certified electrician for proper fuse placement and sizing.

Wire Size and Fuse Rating Chart (AWG)		
Continuous Amps*	Minimum Wire Size**	Fuse Rating
≤60	#6	75-90A
≤80	#4	100-125A
≤100	#2	150A
≤120	#1	175A

Wire Size and Fuse Rating Chart (Metric)		
Continous Amps*	Minimum Wire Size**	Fuse Rating
≤50	10 mm <sup>2</sup>	75-80A
≤70	16 mm <sup>2</sup>	80-90A
≤90	25 mm <sup>2</sup>	125-130A
≤110	35 mm <sup>2</sup>	150A
≤120	50 mm <sup>2</sup>	150-175A

\* For Disconnect mode, this is defined as the maximum continuous amperage being drawn through the ATD by the loads. For ACR mode, this is the charging amperage of the power source (i.e. engine alternator).

\*\* Larger wire sizes may be required to minimize voltage drop in long wire runs. For more information please use the Circuit Wizard at [www.circuitwizard.bluesea.com](http://www.circuitwizard.bluesea.com)

## Installation Diagrams

### Automatic Charging Relay

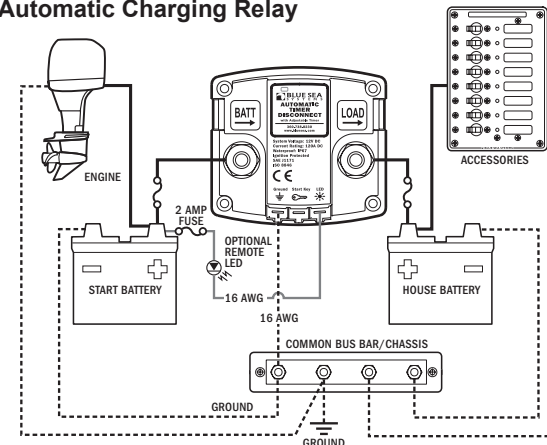

### Legend

DC Positive — DC Negative - - - - - Optional Connection —

**Note:** Because the ATD is single sensing, the battery connected to the charging source must be attached to the stud labeled "BATT". Reversal of the starting and house batteries will create undesirable results.

It is recommended that the ATD be connected directly to your battery positive terminals through appropriately sized fuses. Connecting in a different location such as a battery switch may affect accuracy because of voltage drop along current carrying conductors.

The Start Key terminal is an optional connection when in ACR mode. If connected the ATD will connect anytime an ignition signal is sensed. Once ignition signal is removed the ATD will go back to voltage sensing. If desired, wire the same as the diagram below.

### Timer, Solenoid, or Low Voltage Disconnect

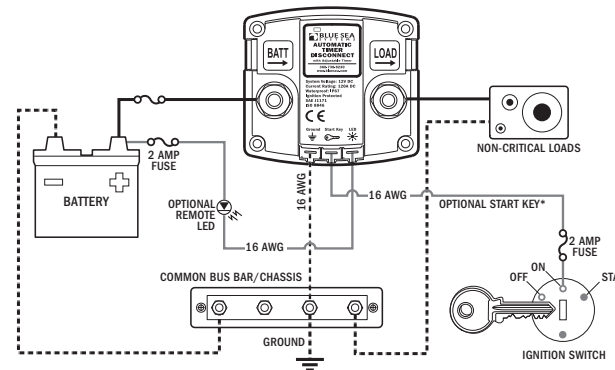

**Note:** Because the ATD is single sensing the battery must be attached to the stud labeled "BATT" and the devices to be disconnected must be attached to the stud labeled "LOAD". Reversal of these connections will render charge sense functionality non-operational.

\* Start Key connection is optional only if "Charge Sense" setting is enabled, to allow the ATD to connect when it senses battery voltage above 13.0V for 3 seconds.



425 Sequoia Drive  
Bellingham, WA 98226 USA  
p 360.738.8230  
[www.bluesea.com](http://www.bluesea.com)

These installation diagrams show typical applications only. Your application may differ.